



INSTALLATION INSTRUCTIONS
Swing Arm Skid Plate Kit
18P-F21A0-V0
2009 YFZ450R

**WARNING**

Please read and understand these instructions completely before installation to avoid possible injury to yourself or damage to the accessory or vehicle.

CAUTION:

This installation should be performed by an authorized Yamaha dealer or a qualified mechanic. Some components require information from the Model's Service Manual for proper installation or adjustment. Be sure to have the Service Manual on hand, if necessary, before proceeding with the installation.

DEALER:

These instructions contain important information for future reference and *must* be given to the customer.

WARRANTY INFORMATION:

- Genuine GYTR components are covered by a 90-day warranty against defects in material or workmanship. Labor for replacement of defective components is not covered. See your Yamaha dealer for a copy of the warranty statement.
- The Limited Warranty provided with new Yamaha vehicles has exclusions for certain failures, including those caused by competition or racing use (except YZ and WR motorcycle models) as well as by abnormal strain or abuse. While installation of these GYTR components will not "void" your vehicle's warranty, specific failures adjudged by Yamaha to have resulted from the installation of accessory components or other modifications, or from competition use (except YZ and WR motorcycle models), may not be covered by warranty or Yamaha Extended Service.

PARTS LIST:

This kit contains the following components. Before beginning installation, confirm there are no missing or damaged components.

Item	Part Number	Description	Qty
--	18P-F21A0-V0	Swing Arm Skid Plate Kit	--
①	*	Swing Arm Skid Plate	1
②	*	Hex Head Flange Bolt (M6 x 1.0 x 25mm LG)	4

* Part supplied with kit only and not available separately.

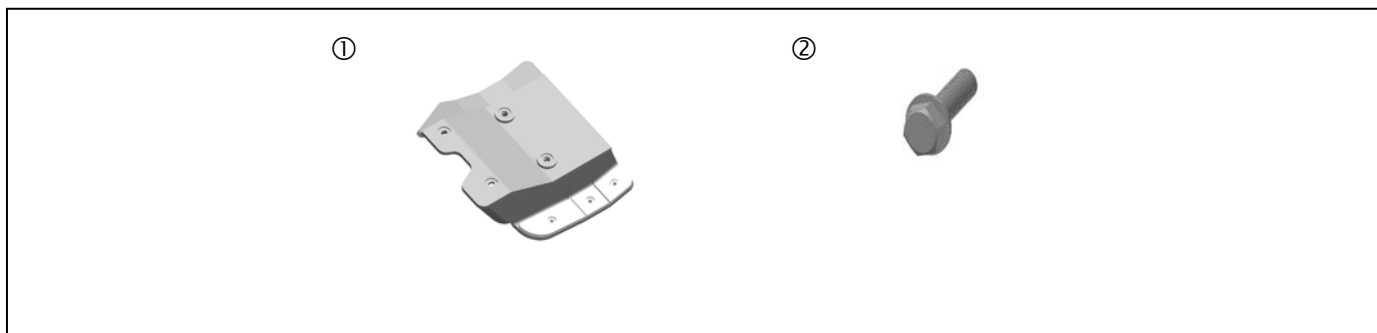
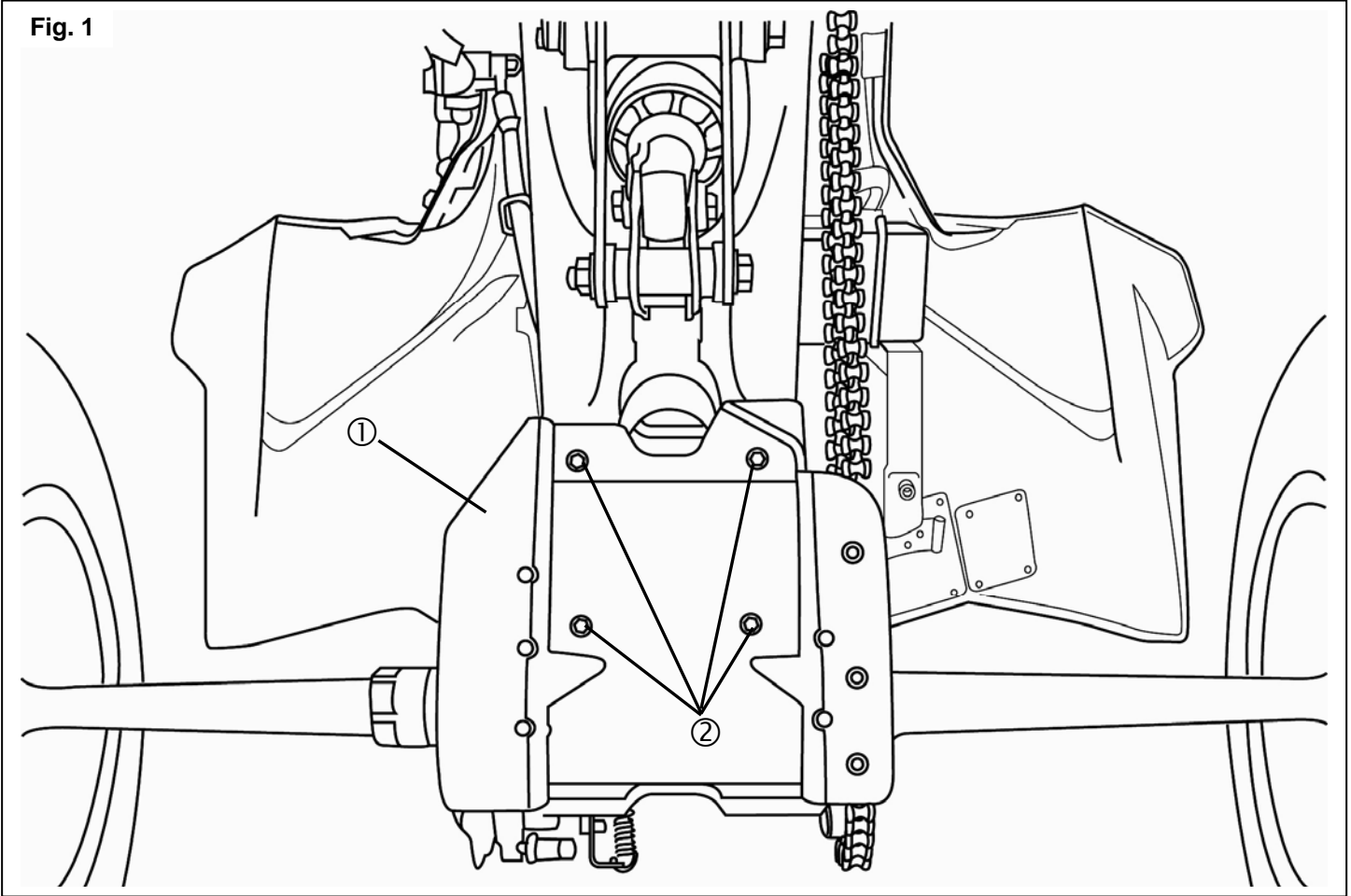

Fig. 1



PREPARATION:

1. Place ATV on a secure level surface and set the parking brake.
2. Clean all mounting surfaces before beginning installation.
3. Turn the gas petcock to the "OFF" position and stand the ATV upright on the rear grab bar.
4. Remove stock swing arm skid plate (Refer to Service Manual).

⚠ WARNING

Be sure the ATV is stable before beginning work. You could be injured if it falls over. Be sure the fuel cap is tightened securely. Leaking fuel is a fire hazard.

INSTALLATION:

NOTE:



Apply Loctite® 242 to all fasteners
Part # ACC-24221-TL-00

1. Install GYT-R skid plate ① onto the swing arm by reversing the removal steps.
2. Secure the skid plate using the hex head flange bolts ② (Fig.1).
3. Torque the bolts to 15 Nm (11 ft • lbs.)

MAINTENANCE:

Periodically, check torque on all hardware. If loose hardware is found, remove hardware, clean off old Loctite®, re-apply fresh Loctite® and re-torque to specification.

CARE AND CLEANING:

Clean using a soft cloth and a non-abrasive metal polisher, such as Simichrome Polish (P/N: ACC-1100-19-01).

CUSTOMER SERVICE:

For further information, see your Yamaha dealer.

ESTIMATED TIME TO INSTALL: 0.2 HRS