



INSTALLATION INSTRUCTIONS

Drain Plug Kit
18P-E51C0-V0 (Blue)
18P-E51C0-U0 (Red)
Fits Multiple Models



⚠ WARNING

Please read and understand these instructions completely before installation to avoid possible injury to yourself or damage to the accessory or vehicle.

CAUTION:

- This installation should be performed by an authorized Yamaha dealer or a qualified mechanic. Some components require information from the model's Service Manual for proper installation or adjustment. Be sure to have the Service Manual on hand, if necessary, before proceeding with the installation.
- Alteration of emission-related components constitutes tampering under Federal and State laws and can lead to substantial fines and penalties if used other than in closed-course competition.
- Engine-related competition parts are intended for only closed-course racing applications.

DEALER:

These instructions contain important information for future reference and *must* be given to the customer.

WARRANTY INFORMATION:

- Genuine Yamaha GYTR components are covered by a 90 day warranty against defects in material or workmanship. Labor for replacement of defective components is not covered. See your Yamaha dealer for a copy of the warranty statement.
- The Limited Warranty provided with new Yamaha vehicles has exclusions for certain failures, including those caused by competition or racing use (except YZ and WR motorcycle models) as well as by abnormal strain or abuse. While installation of these GYTR components will not "void" your vehicle's warranty, specific failures adjudged by Yamaha to have resulted from the installation of accessory components or other modifications, or from competition use (except YZ and WR motorcycle models), may not be covered by warranty or Yamaha Extended Service.

PARTS LIST:

This kit contains the following components. Before beginning installation, confirm there are no missing or damaged components.

Item #	Part Number	Description	Qty
--	18P-E51C0-XX	Drain Plug Kit	--
①	*	Drain Plug	1
②	90430-10171-00	Gasket	1

* Part supplied with kit only and not available separately.

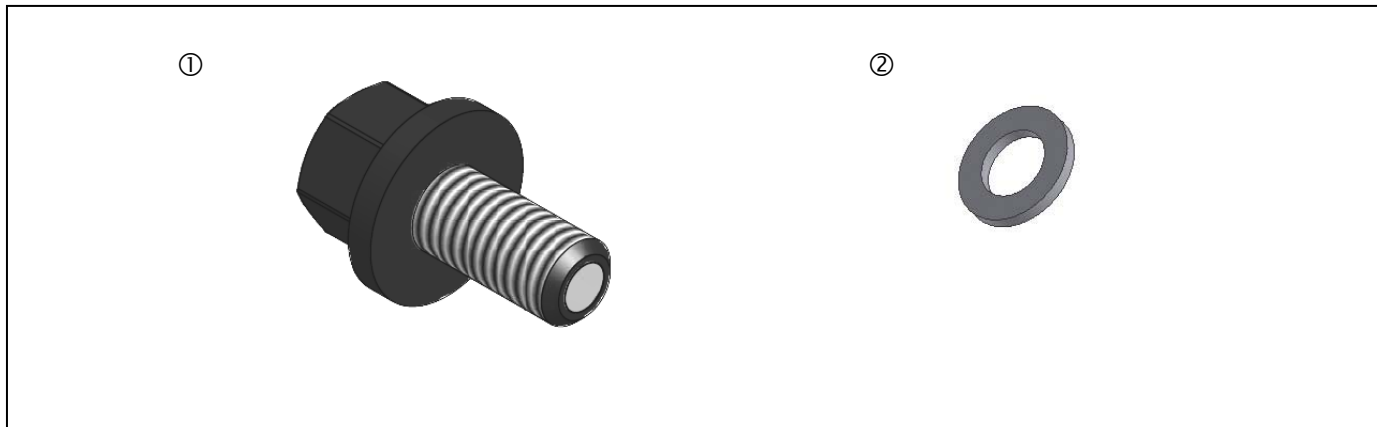

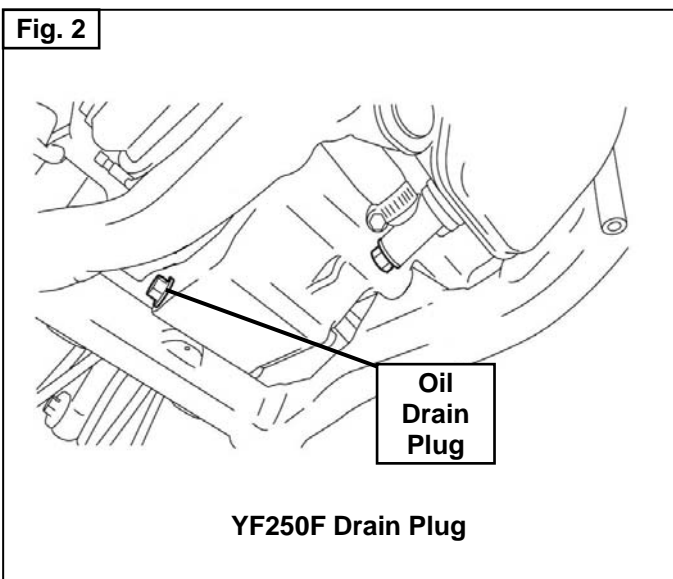
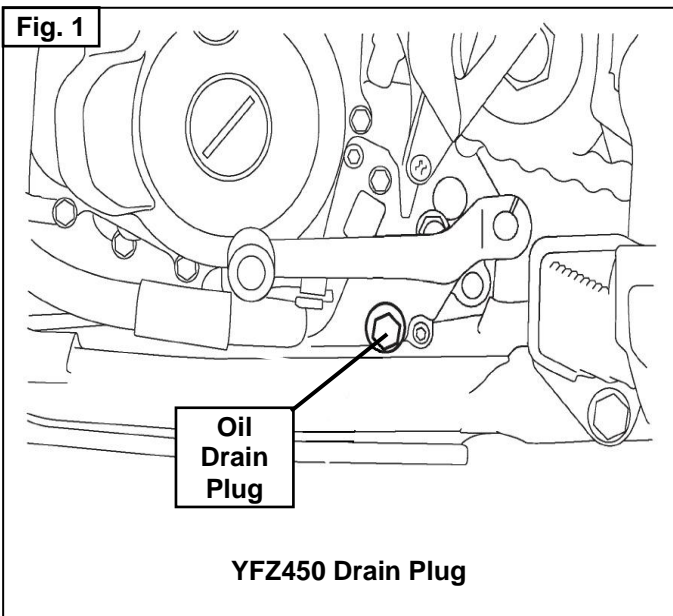

PREPARATION:

- Place unit on a secure and level surface and set the parking brake.
- Clean all mounting surfaces before beginning installation.

INSTALLATION:

- Start the vehicle and let it warm up briefly.
- Stop the engine and place a drain pan under the drain bolt. Remove the drain bolt and old crush washer.

⚠ WARNING

The oil draining from the engine will be extremely hot. Take appropriate safety precautions to avoid injury.

- After the oil has drained, install the new drain bolt, being sure to use the new crush washer. Torque to 17.1 Nm (12.6 Ft-lb).
- It is recommended to replace the oil filter at this time.

MAINTENANCE:

When performing future oil changes, inspect the magnetic portion of the drain bolt upon removal. The magnet will attract ferrous material, which will need to be cleaned from the bolt before re-installation. Periodically, check all hardware for tightness and re-torque as required.

CARE AND CLEANING:

Wash using a mild soap and water solution and soft cloth.

CUSTOMER SERVICE:

For further information, see your Yamaha dealer.

ESTIMATED TIME TO INSTALL: 0.1 HRS