



INSTALLATION INSTRUCTIONS  
FRONT A-ARM SKID PLATES  
ABA-3B432-00-00  
2007 YFM700FWA



**WARNING**

Please read and understand these instructions completely before installation to avoid possible injury to yourself, or damage to the accessory or vehicle.

**CAUTION:**

- This installation should be performed by an authorized Yamaha dealer or a qualified mechanic. Some components require information from the model's service manual for proper installation or adjustment. Be sure to have the service manual on hand, if necessary, before proceeding with the installation.
- Alteration of emission-related components constitutes tampering under Federal and State laws and can lead to substantial fines and penalties if used other than in closed-course competition.
- Engine-related competition parts are intended for closed-course racing applications only.

**DEALER:**

These instructions contain important information for future reference and *must* be given to the customer.

**WARRANTY INFORMATION:**

- Genuine Yamaha components are covered by a 90-day warranty against defects in material or workmanship. Labor for replacement of defective components is not covered. See your Yamaha dealer for a copy of the warranty statement.
- The Limited Warranty provided with new Yamaha vehicles has exclusions for certain failures, including those caused by competition or racing use (except YZ and WR motorcycle models) as well as by abnormal strain or abuse. While installation of these components will not "void" your vehicle's warranty, specific failures adjudged by Yamaha to have resulted from the installation of accessory components or other modifications, or from competition use (except YZ and WR motorcycle models), may not be covered by warranty or Yamaha Extended Service.

**1. PARTS LIST:**

This kit contains the following components. Before beginning installation confirm there are no missing or damaged components.

Item #	Part Number	Description	Qty
1	*	Left Skid Plate, Aluminum	1
2	*	Right Skid Plate, Aluminum	1
3	*	Hook 1	2
4	*	Hook 2	4
5	*	Flange Bolt, M6x1.0x16mm	8
6	*	Nylon Locknut, M6	2

\* Part supplied with kit only and not available separately.

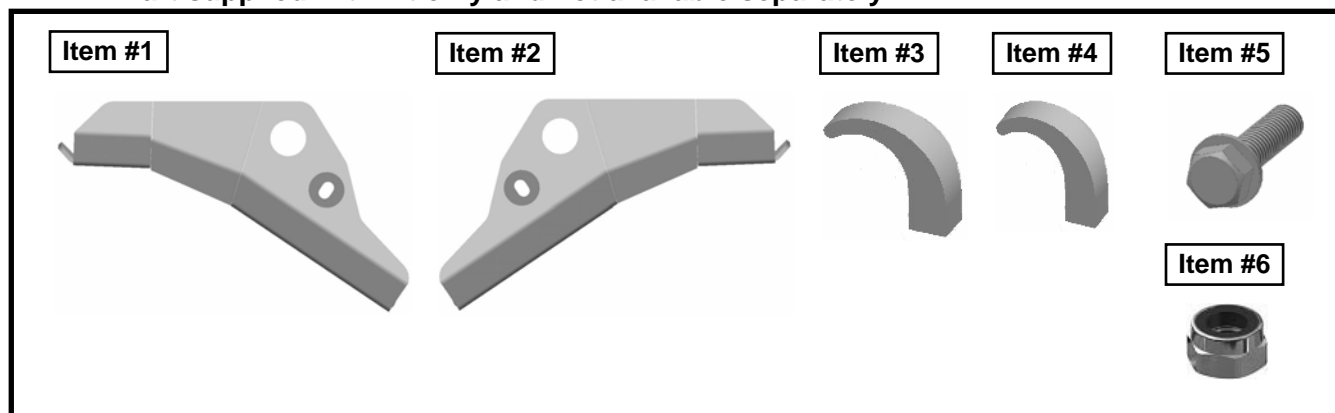

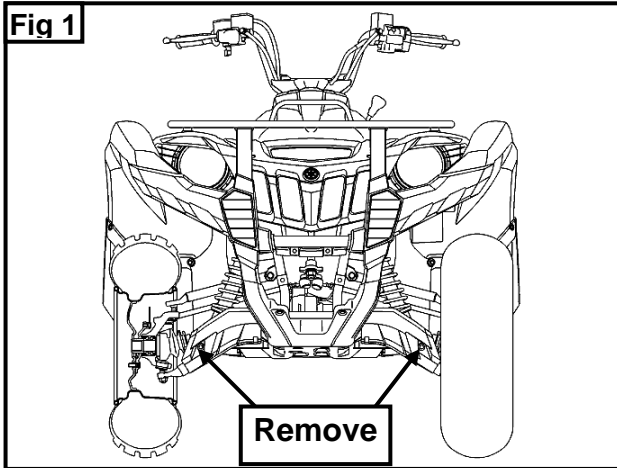

**PREPARATION:**

- Place vehicle on a secure level stand, put the transmission into Park and set the parking brake.
- Clean all mounting surfaces before beginning installation.
- Remove the stock plastic guards by removing the mounting screw on each guard. The screws will not be reused.

**2. INSTALLATION:**

**NOTE:**

Use Loctite® 242 Threadlocker on each fastener to prevent loosening while riding.

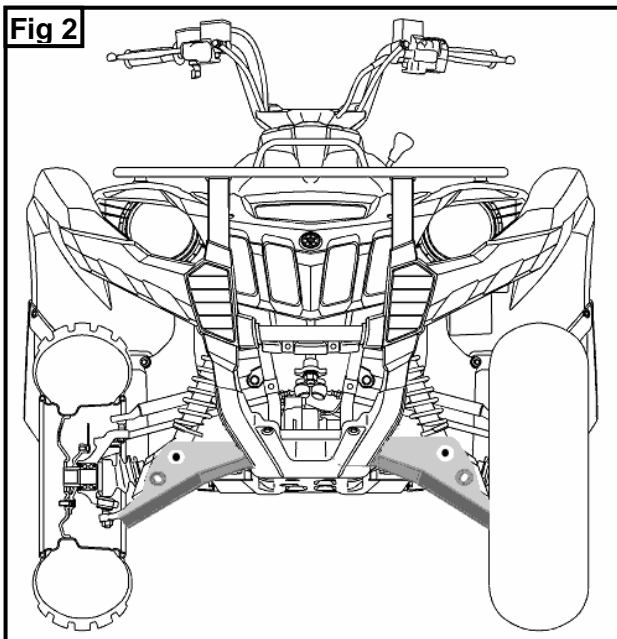

- Thread the supplied flange bolts through the guards and into the hooks finger-tight. Use the larger hooks in the location shown in Fig 3. It may ease installation if the hooks are faced towards the center of the guard and then rotated into place after the guard has been positioned.
- Position the hooks over the a-arms. Thread a bolt through the front mounting hole on each guard and install a locknut on the back side of each bolt.
- Position guards and torque all fasteners to 8 Nm (6 ft • lb).

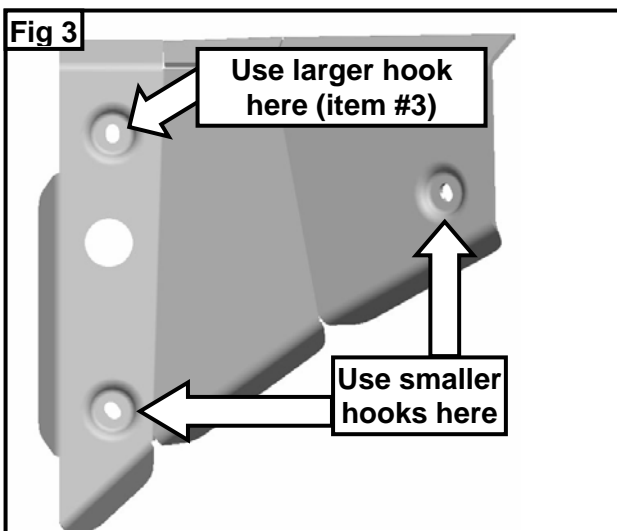

**3. MAINTENANCE:**

Periodically check all hardware for tightness and re-torque as required.

**4. CARE AND CLEANING:**

Wash using a mild soap and water solution and soft cloth.

**5. CUSTOMER SERVICE:**

For further information see your Yamaha dealer.